

NOTE: Use RG-59U, or equivalent, coaxial cable for HV connections, and RG-62U or RG-59U for signal connections.

In applications where spectrum energy analysis is desired, the output of the amplifier (refer to Fig. 1) should be connected to the high level input of a multichannel analyzer. Spectra for most common gamma emitters obtained with a 3" x 3" NaI(Tl) detector can be found in "Scintillation Spectrometry, Gamma Ray Spectrum Catalog" by R. L. Heath, IDO-16408, Phillips Petroleum Company, Atomic Energy Division.

If your detector is supplied with a stainless steel low background tube base, signal connections can be made directly. Detectors supplied with standard 12 or 14-pin phenolic bases require a voltage divider to integrate them into the signal processing electronics. A typical POSITIVE high voltage divider circuit is illustrated in the following diagram (corresponds to Harshaw Type POB-4):

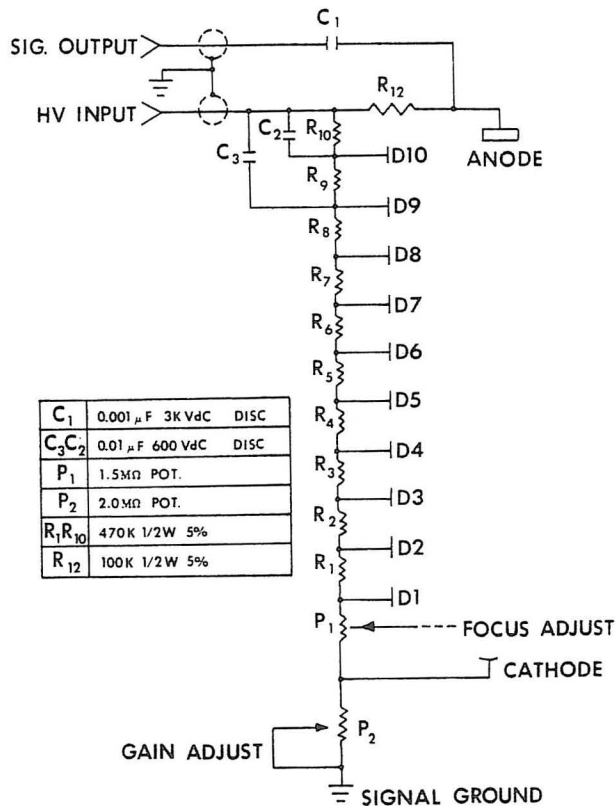

FIGURE 2

Representative POSITIVE High Voltage divider circuit used in pulse mode spectrometry applications. Corresponds to Harshaw Type POB-4 (14-pin base). A 12-pin base configuration is also available (Type POB-2).

CAUTION: ONLY INTEGRAL<sup>®</sup> LINE AND MATCHED WINDOW<sup>®</sup> LINE DETECTORS SPECIFICALLY ORDERED FOR NEGATIVE HIGH VOLTAGE OPERATION SHOULD BE USED IN THIS FASHION. FAILURE TO OBSERVE THIS WARNING MAY RESULT IN DAMAGE TO THE PHOTOMULTIPLIER TUBE AND SEVERE SHOCK HAZARD. THE OUTER HOUSING OF THE DETECTOR MUST BE GROUNDED AT ALL TIMES.

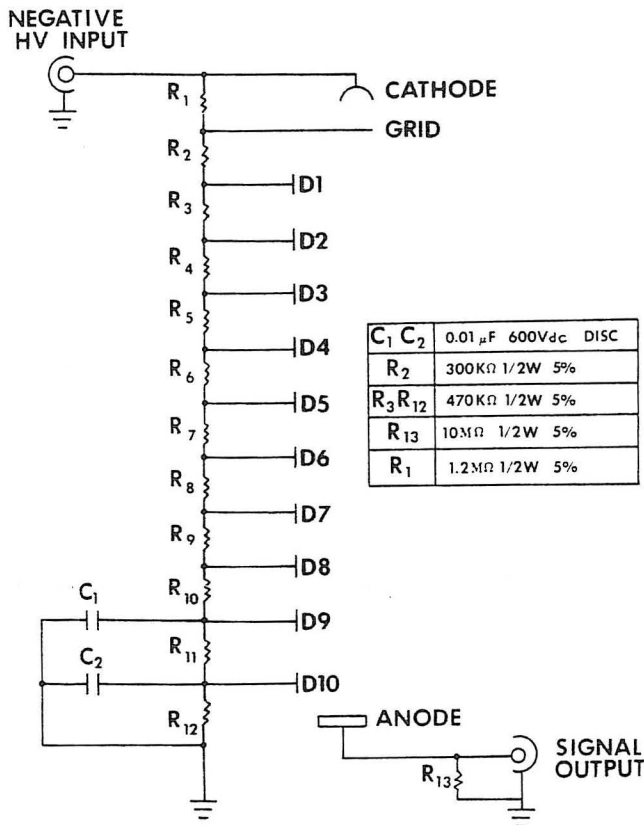
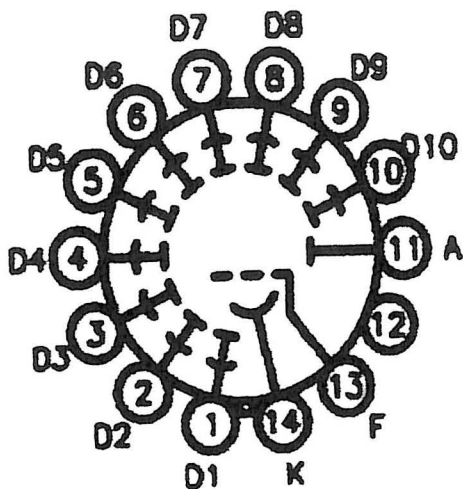

FIGURE 4

Representative NEGATIVE High Voltage divider circuit used to measure PMT anode current. Corresponds to Harshaw Type POB-9 (14-pin base).

The anode signal can be connected to an integrating picoammeter such as Harshaw's Model 2000B or other sensitive dc amplifier.

In this mode of operation, the photocathode and an external coating applied on the glass envelope of the tube are operated at the negative high voltage potential. This prevents current leakage through the glass from damaging the photocathode. An insulating layer between the outer shielding and the external coating permits the outer shielding to be grounded. For safety reasons, no voltage should be applied unless this ground connection is made.



**BOTTOM VIEW  
WITH BASE**

**D-DYNODE  
A-ANODE  
K-CATHODE  
F-FOCUS**