

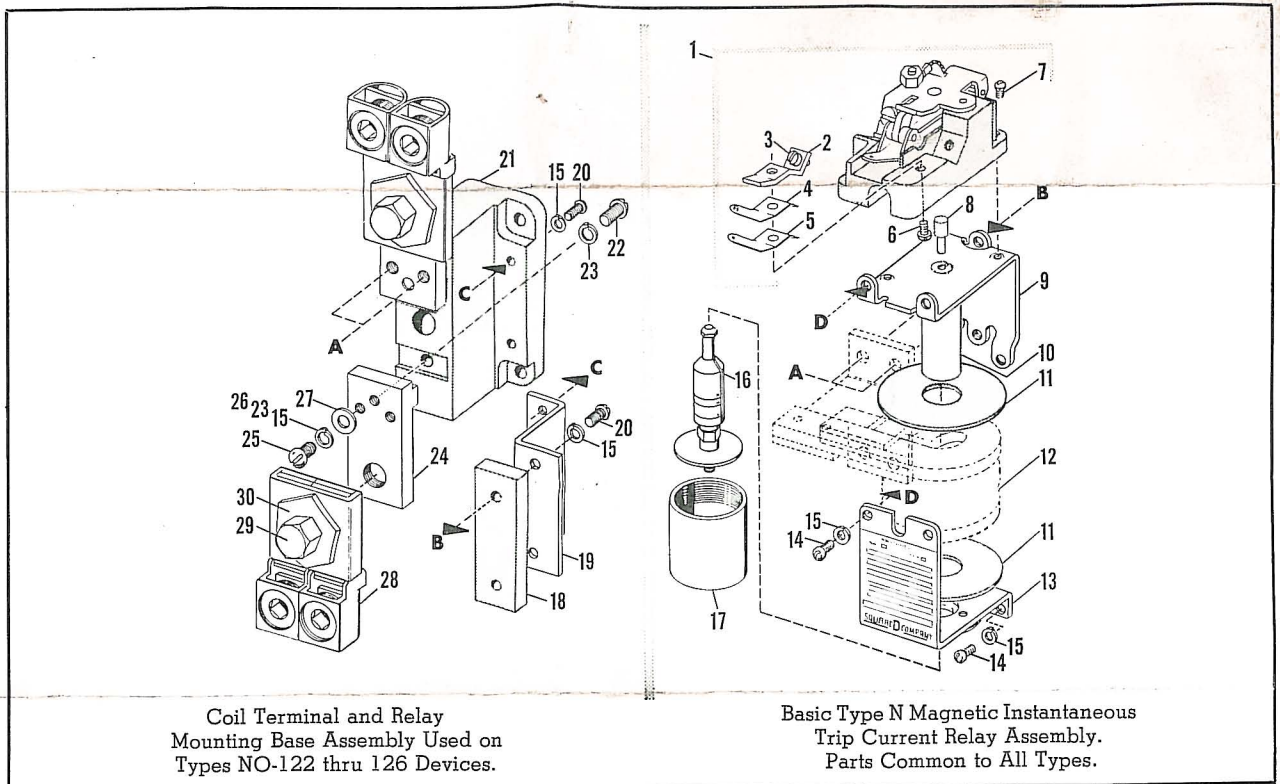

**Class 9055 — Dashpot Type — Magnetic Current Relays**  
**Type N, Series A**  
**Instantaneous Trip Type**



Coil Terminal and Relay Mounting Base Assembly Used on Types NO-122 thru 126 Devices.

Basic Type N Magnetic Instantaneous Trip Current Relay Assembly. Parts Common to All Types.

**Application** — Type N overload relays provide instantaneous trip operation on any current greater than the trip current setting. Relays with this feature are often used for baler control, where it is necessary to stop the motor when the full load current reaches the point corresponding to the required baling pressure. On conveyor systems, Type N relays are used to stop the conveyor when a jam occurs, preventing damage to materials and machinery. The RESET CURRENT is approximately 80% on ac and 67% on dc of the trip current setting. RESET TIME is very fast as no dashpot oil is used.

**Contact Assembly** — The contact assembly, Item 1, is of unit construction and can be removed by loosening two screws, Item 7. With the contact assembly, Item 1, removed, the stationary leaf contact, Item 4, can then be removed by removing stationary contact assembly holder screw, Item 6. Reassemble in the reverse manner making sure that leaf contact, Item 4, is in its proper position between the leaf spring, Item 5, and contact terminal, Item 2. Likewise, make sure the loose trip pin,

Item 8, has not fallen from the upper frame, Item 9, but is in its proper position when remounting the contact block assembly, Item 1, to the upper frame, Item 9.

**Setting Current Trip Point** — Unscrew dashpot, Item 17, and remove plunger and piston assembly, Item 16. While holding the piston and plunger assembly, Item 16, in one hand apply a wrench to the hexagon shaped head at the top of the adjusting screw which passes through the center of the plunger. Turn the adjusting screw until the red indicator mark on it, as seen through the slot in the side of the plunger, is in agreement with the desired trip setting when correlated with the scale marked H (high) — M (medium) — L (low) on the side of plunger. The adjusting screw is self-locking in the piston and plunger assemblies, Item 16. The H-M-L scale markings on the plunger correspond to the high, medium and low trip current values respectively as given on the device nameplate. It may be necessary to repeat the adjusting procedure above if the trip point is not close enough to the desired trip point needed.

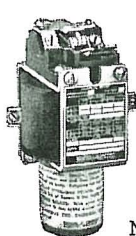

Fig. a  
NO-101-116



Fig. b  
NO-117-121

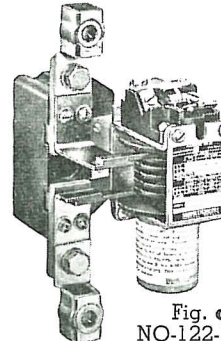

Fig. c  
NO-122-126

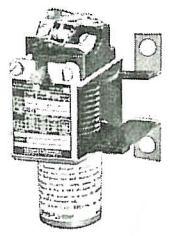

Fig. d  
NO-167-176

Figures a, b, c, & d show the four standard mounting arrangements and type coil for each. Photos a, b, and c are arrangements for steel panel mounting, and Photo d arrangement is for insulating panel mounting.

New Sheet

**SQUARE D COMPANY**



**ORDERING INSTRUCTIONS:** Specify quantity, part number, and description of part, giving complete nameplate data of the device. For example: 1-750-C34-G4, contact assembly complete, for Class 9055 Type NO-110 with Serial No. 204642-750-S670-G10

Item No.	Description	Part Number	PARTS LIST								
			Fig. a		Fig. b		Fig. c				Fig. d
			NO-101 thru NO-116	NO-117 L or R thru NO-119 L or R	NO-120 L or R and NO-121 L or R	NO-122 L or R and NO-123 L or R	NO-124 L or R	NO-125 L or R	NO-126 L or R	NO-167 L or R thru NO-176 L or R	
1	Contact Assy Complete	750-C34-G4	1	1	1	1	1	1	1	1	
2	Stationary Contact Terminal	750-D14-X2	1	1	1	1	1	1	1	1	
3	Terminal Screw #8-32x1/4"	1501W1408	2	2	2	2	2	2	2	2	
4	Stationary Leaf Contact	750-G1	1	1	1	1	1	1	1	1	
5	Stationary Contact Leaf Spring	750-L35-X1	1	1	1	1	1	1	1	1	
6	Screw #8-32x1/4"	1901W14081	1	1	1	1	1	1	1	1	
7	Screw #8-32x1/16"	1902W14141	2	2	2	2	2	2	2	2	
8	Trip Pin	750-X6B	1	1	1	1	1	1	1	1	
9	Upper Frame	750-D2-G1	1	1	1	1	1	1	1	1	
10	Fibre Tube	750-X15	1	1	1	1	1	1	1	1	
11	Coil Washer	153-D15-X4	3	.....	.....	.....	.....	.....	.....	.....	
	Coil Washer	739-D13-X1	.....	2	2	.....	.....	.....	.....	.....	
	Coil Washer	153-D1-X6	.....	.....	.....	2	2	2	2	2	
12	Magnet Coil	See Coil Table Below	1	1	1	1	1	1	1	1	
13	Lower Frame	750-D3-G1	1	1	1	1	1	1	1	1	
14	Screw #10-24x3/16"	1001W1610	4	4	4	4	4	4	4	4	
15	Lockwasher #10	3701W16	4	4	4	12	8	8	8	4	
16	Plunger and Piston Ass'y	750-D158-G1	1	1	1	1	1	1	1	1	
17	Dashpot	750-D71-X1	1	1	1	1	1	1	1	1	
18	Spacer	750-D146-X1	.....	.....	.....	.....	1	1	1	.....	
19	Support Bracket	750-L33-X1	.....	.....	.....	1	1	1	1	.....	
	Support Bracket	750-L36-X1	.....	.....	.....	.....	.....	.....	.....	1	
20	Screw #10-24x3/8"	1001W1612	.....	.....	.....	2	2	2	2	.....	
	Screw #10-24x3/8"	1001W1620	.....	.....	.....	2	2	4	2	.....	
21	Coil Term. & Relay Mtg. Base	31006-039-01	.....	.....	.....	1	1	1	1	.....	
22	Screw 1/4-20x3/8"	1001W2028	.....	.....	.....	2	2	2	2	.....	
23	Lockwasher 1/4"	3701W20	.....	.....	.....	2	6	6	2	.....	
24	Lug Terminal	750-D139-X1	.....	.....	.....	2	.....	.....	2	.....	
	Lug Terminal	750-D138-X1	.....	.....	.....	.....	2	2	.....	.....	
25	Screw #10-24x1/16"	1001W1614	.....	.....	.....	4	.....	.....	.....	.....	
	Screw 1/4-20x1/3"	1001W2016	.....	.....	.....	.....	4	4	.....	.....	
26	Hex. Hd. 3/8-16x7/8"	1401W2428	.....	.....	.....	.....	.....	.....	2	.....	
	Lockwasher 3/8"	3701W24	.....	.....	.....	.....	.....	.....	.....	.....	
27	Washer #10	3601W16	.....	.....	.....	4	.....	.....	.....	.....	
	Washer 1/4"	3601W20	.....	.....	.....	.....	4	4	.....	.....	
	Washer 3/8"	3601W24	.....	.....	.....	.....	.....	.....	2	.....	
28	Terminal Lug Ass'y	281-M2-G1	.....	2	.....	.....	.....	.....	.....	.....	
	Terminal Lug Ass'y	281-M2-G2	.....	.....	2	.....	.....	.....	.....	.....	
	Terminal Lug	5011W10	.....	.....	.....	2	.....	.....	.....	.....	
	Terminal Lug	5011W9	.....	.....	.....	.....	2	2	.....	.....	
	Terminal Lug	5011W5	.....	.....	.....	.....	.....	.....	2	.....	
29	Hex. Hd. 3/8-16x3/4"	1401W2424	.....	.....	.....	2	.....	.....	.....	.....	
	Hex. Hd. 1/2-13x1 1/4"	1401W2832	.....	.....	.....	.....	2	2	.....	.....	
	Hex. Hd. 1/2-13x1 3/4"	1401W2856	.....	.....	.....	.....	.....	.....	2	.....	
30	Lockwasher 3/4"	3701W24	.....	.....	.....	2	.....	.....	.....	.....	
	Lockwasher 1/2"	3709W8	.....	.....	.....	.....	2	2	.....	.....	
	*Lockwasher 1/2"	3701W28	.....	.....	.....	.....	.....	.....	2	.....	
	*Washer 1/4"	3601W28	.....	.....	.....	.....	.....	.....	2	.....	
	*Hex. Nut 1/2-13	3002W28	.....	.....	.....	.....	.....	.....	2	.....	

†Terminal lug assembly consists of a lug, screw, nut, washer, and lock washer.  
 ‡Not physically the same shape as shown on exploded drawing. \*Not shown on exploded drawing.

### CONVERSION OR REPLACEMENT PARTS FOR FORM HR; FORM Y44; OR FORM HR, Y44 ON TYPE N MAGNETIC RELAYS

**Form HR** — Refers to a hand reset contact mechanism with reset button lever as opposed to the automatic reset contact mechanism supplied on standard devices as in Item 1 above.

**Form Y44** — Refers to a contact mechanism with 1 normally open contact as opposed to the 1 normally closed contact on the contact mechanism supplied on standard devices.

PARTS LIST FOR FORM HR; Y44; OR HR, Y44						
Item No.	Description	Part Number	Form HR	Form Y44	Form HR, Y44	
AA	* *Contact Block Assembly Complete	750-D150-G1	1	.....	.....	.....
BB	* *Contact Block Assembly Complete	750-C34-G3	.....	1	.....	.....
CC	* *Contact Block Assembly Complete	750-D150-G2	.....	.....	1	.....
DD	*Reset Button Lever	750-D151-X1	1	.....	.....	1

\* \*Not shown on exploded drawing, but similar in physical shape to Item 1. \*Not shown on exploded drawing.

MAGNET COIL SELECTION TABLE											
Type NO- (R or L Hand)	Photo Fig.	Magnet Coil Item 12 Above	Type NO- (R or L Hand)	Photo Fig.	Magnet Coil Item 12 Above	Type NO- (R or L Hand)	Photo Fig.	Magnet Coil Item 12 Above	Type NO- (R or L Hand) ▲	Photo Fig.	Magnet Coil Item 12 Above
NO-101	a	739-S26-W26	NO-110	a	739-S26-W17	NO-119	b	739-S5-W7	NO-168R	d	739-S1-W6R
									NO-168L	d	739-S1-W6L
NO-102	a	739-S26-W25	NO-111	a	739-S26-W16	NO-120	b	739-D14-G1	NO-169R	d	739-S14-W6R
									NO-169L	d	739-S14-W6L
NO-103	a	739-S26-W25A	NO-112	a	739-S26-W15	NO-121	b	739-D15-G1	NO-170	d	739-D1-G1
NO-104	a	739-S26-W24	NO-113	a	739-S26-W14	NO-122	c	750-D142-G4	NO-171	d	739-D2-G1
NO-105	a	739-S26-W24A	NO-114	a	739-S26-W13	NO-123	c	750-D142-G3	NO-172	d	739-D70-G1
NO-106	a	739-S26-W22	NO-115	a	739-S26-W12	NO-124	c	750-D135-G1	NO-173	d	739-D3-G1
NO-107	a	739-S26-W21	NO-116	a	739-S26-W10	NO-125	c	750-D143-G1	NO-174	d	739-D59-G1
NO-108	a	739-S26-W20	NO-117	b	739-S5-W8	NO-126	c	750-F94-G1	NO-175	d	739-D56-G1
NO-109	a	739-S26-W18	NO-118	b	739-S5-W6	NO-167	d	739-S1-W8	NO-176	d	739-D68-G1

▲Exception — Types NO-168R, 168L, 169R, and 169L each use separate right and left hand coils.