



QuikKit
by *Nortronics*

**CARTRIDGE MOUNT
ASSEMBLIES**

THE NORTRONICS COMPANY, INC. 8101 TENTH AVENUE NORTH MINNEAPOLIS, MINNESOTA 55427

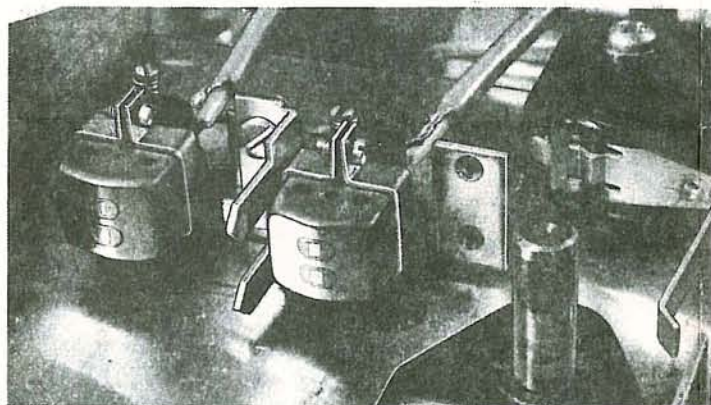

FIG. 1. ATC INSTALLATION (SHOWN WITH SPRING CLIP REMOVED)

DESCRIPTION

The QK-114, 115, and 117 cartridge mount assemblies, created for use with Nortronics no-mount heads, offer the users of Fidelipac type cartridge tape equipment precise adjustments for height, face and azimuth alignment. Provision is also made to provide the proper tape head wrap insuring good tape-to-gap contact. These Quik-Kits are supplied assembled, semi-aligned and with all necessary hardware for simple installation on most cartridge decks.

The QK-114 will accept any two no-mount Nortronics 2, 3, or 4 channel stereo heads (see Table 1).

The QK-115 will accept any two no-mount Nortronics series 3000 or 3200 two-track mono heads (see Table 1).

The QK-117 is a hybrid assembly of the two above Quik-Kits, accepting one mono head and one stereo head (see Table 1).

HEAD WIRING

Regardless of the type of installation to be made, do *not* remove the wires from any heads on the recorder until the correct identification procedure is followed. See General Instructions on Nortronics Form No. 7077.

INSTALLATION OF HEADS

The same general installation instructions apply to all three Quik-Kits. All references made to right and left in the following instructions are made when looking at the face of the heads.

Determine the proper location on your Quik-Kit for the new Nortronics heads. The position for the various types of heads will be determined by which of the Quik-Kits and heads you are mounting and their intended use. *In general*, when using the QK-115 with mono two-track no-mount heads, the head to the left is the program head and is mounted with the track up; the head to the right (the head nearest capstan) is the cue head and is mounted with the track down.

The QK-114 uses two-track stereo heads. The head to the left is a record-only head for both program and cue channels, and the head to the right is a playback-only head.

The QK-117 uses a two-track mono record-only head for the upper program channel in the left position. The head to the right is a two-track stereo head for "program play" and "cue record and play".

By updating the machine with QK-117, you can now monitor a program being recorded. A large number of earlier machines do not have this desirable feature.

When the proper heads have been selected and their positions located, slide them into the head brackets until the rear edge of the head case is just even with the back corner of the small step at the top rear of the head clamp. Tighten the clamp screws to lock the heads in place. Place the assembly on a flat surface. Make certain the fork guide clears the sides of the head bracket to allow for azimuthing and that the base of the guide is just resting on the surface. If the guide is tipped or raised, the guiding action will be incorrect.

TABLE 1. HEAD TYPES AVAILABLE FOR USE IN QK-114, 115, 117

USE QK-114 WITH THESE NORTRONICS "B" SIZE HEADS: 1000 thru 1049, 1200 thru 1249, 1800 thru 1849, 2000 thru 2049 4100 thru 4149, 5600 thru 5649, 5700 thru 5749
USE QK-115 WITH THESE NORTRONICS "G" SIZE HEADS: 3000 thru 3049, 3200 thru 3249
USE QK-117 WITH ONE NORTRONICS "B" SIZE HEAD: 1000 thru 1049, 1200 thru 1249, 1800 thru 1849, 2000 thru 2049 4100 thru 4149, 5600 thru 5649, 5700 thru 5749 AND ONE NORTRONICS "G" SIZE HEAD: 3000 thru 3049, 3200 thru 3249

Adjust the head height and face perpendicularity using the alignment guide Nortronics Form No. 7195 provided with the kit. Using the allen wrench provided, raise or lower the head bracket height adjustment screws until the head tracks are in proper alignment with the tape track on the card and the face of the head is parallel to the vertical edge of the card.

Loosen azimuth lock screw, and if necessary, adjust the azimuth screw so that the head sets square in the assembly.

REMOVING OLD HEAD ASSEMBLY - **See note below for Collins. Disconnect or unsolder the leads to the old head assembly. Remove the screws which secure the head nest to the deck plate, and discard the old head nest.

INSTALLING NEW CARTRIDGE MOUNT

Several machines have a micro switch mounted just to the rear of the capstan. On these models it is necessary to raise the micro switch by approximately 3/32 in. Remove the screws holding the switch to the deck plate and insert two space washers under each screw. Secure the switch to the deck plate by reinstalling the two screws.

Place the template card, Form No. 7204, on the deck plate with the right hand edge of the card flush with the cartridge guide rail and the capstan centered on the capstan center line marking on the guide. Holding the template securely, center punch the three holes to be drilled as indicated on the template. Drill the three holes using a #33 drill. **CAUTION:** Be careful not to damage the mechanism beneath the deck surface by allowing the drill to penetrate too deeply.

Install the new head bracket assembly using the 6-32 self tapping screws and washers provided. Do not tighten screws.

Insert a cartridge into the machine tight against the guide rail and position it so there is approximately 1/32 in. clearance between the cartridge and the capstan. Holding the cartridge firmly in this position, align the bracket assembly so it is parallel to the front edge of the cartridge, the stop on the fork guide is touching the cartridge, and the heads and fork guide are approximately centered in the cartridge windows. Make certain the fork does not hit the plastic boss inside the Fidelipac cartridges. With the head bracket properly positioned, tighten the self tapping screws.

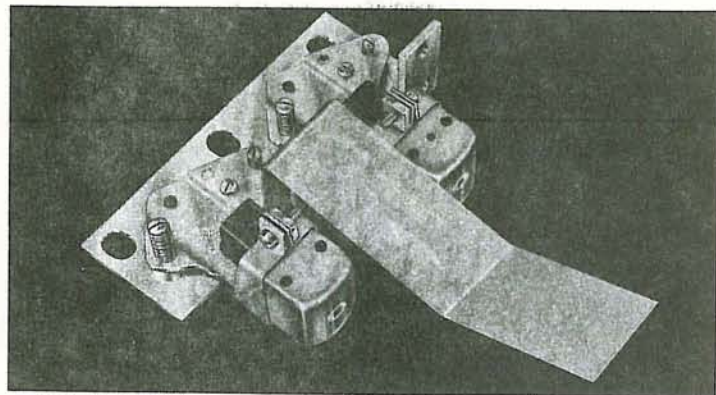

FIG. 2. QK-114, WITH HEADS MOUNTED AND WITH SPRING CLIP

**The Collins Models 642-A1 and 642-A2 cartridge tape transports have a mu-metal shield plate mounted on the deck surface. The rear edge of this shield is turned up to form a vertical panel on which the rear-mount heads are installed. In order to mount the QK-114 or 117 on these Collins units, it is necessary to cut away a portion of the turned-up shield plate to prevent interference with the Quik-Kits. First, remove the rear-mount heads and their mounting channel, MP-130. Then remove the shield plate, MP-133. Use tin snips to cut out that portion of the vertical panel of the shield plate which lies between the two angle brackets which support the plate on either side of the head assembly. The shield plate should then be re-installed on the deck again using the angle brackets to support the vertical panel. The Quik-Kit should now fit into the cut away area. Make certain that the forward edge of the Quik-Kit base does not rest on a ragged edge of the mu-metal plate.

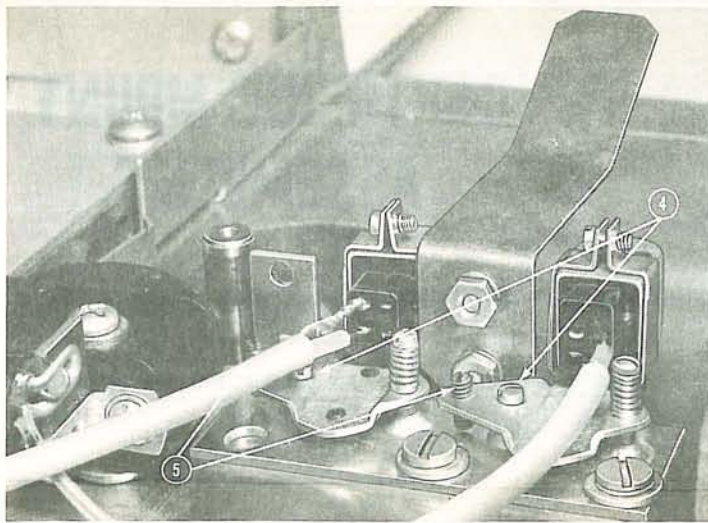
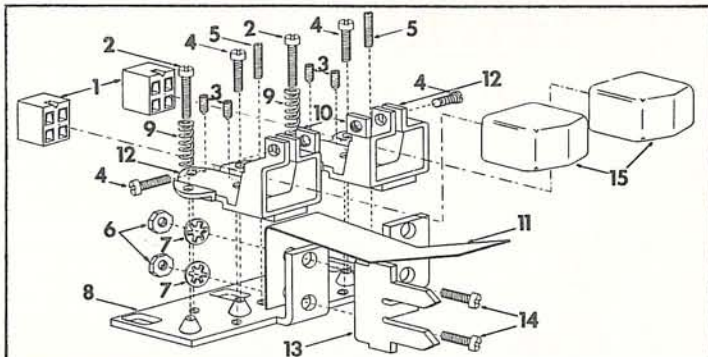

FIG. 3. REAR VIEW, INSTALLED BRACKET



ITEM	QUANTITY			PART NO.	DESCRIPTION
	QK-114	QK-115	QK-117		
1	2	2	2	105-20	Plug
2	2	2	2	119-27	#2-56 X 1/2 Fil. Hd. Screw
3	4	4	4	119-56	#4-40 X 3/16 Cone Pt. Set Screw
4	4	4	4	119-44	#2-56 X 1/4 Fil. Hd. Screw
5	2	2	2	119-72	#4-40 X 5/16 Cup Pt. Set Screw
6	2	2	2	116-3	#4-40 Hex Nut
7	2	2	2	115-4	#4 Internal Tooth Lockwasher
8	1	1	1	123-45	Base Channel
9	2	2	2	148-13	Spring, Compression
10	2	2	2	116-24	#2-56 Square Nut
11	1	1	1	148-20	Spring Clip
12	2	-	1	500-156	B-Head Clamp & Bracket Ass'y
12	-	2	1	500-155	G-Head Clamp & Bracket Ass'y
13	2	1	1	173-16	Tape Guide & Cartridge Stop
14	2	2	2	119-6	#4-40 X 1/4 Binding Hd. Screw
15	Nortronics No-Mount Head (not included in kit)				

FIG. 4. EXPLODED VIEW

WIRING THE HEADS

Connector plugs are provided for installation on the head cables, and if the instructions are followed using a pencil type iron with a small sharp tip, no serious difficulty should be encountered in soldering the cable leads to the plugs. DO NOT SOLDER LEADS DIRECTLY TO THE HEAD PINS! First, cut the phono plugs from the cables and then strip and tin about 1/16 inch of the ends of the leads. Then, clamp the plug in a small vise or C-clamp so that the terminal tabs are pointing up and the back surface of the plug is horizontal. Next, carefully flow a small amount of solder on each of the two right-hand terminal tabs when the plug is oriented so that the end with the notch is facing the operator. This will insure that the leads are connected to the correct plug terminals for the mono heads with two pins. Plugs for the 4-pin stereo heads should have all four terminals tinned. Finally, tack the tinned lead ends to the plug terminals.

THREE-CHANNEL HEADS There is no connector plug for the three-channel 5700 series heads used with the QK-114 on the stereo cartridge machines. Instead, the individual #109-54 terminal clips must be soldered to the ends of the cable leads. See Nor-Form No. 7077 packed with each Nortronics head.

AZIMUTH - ALIGNMENT

Insert a standard alignment test tape into the machine and play the high frequency azimuth alignment tone. Loosen the azimuth lock screws (No. 5 Fig. 3), adjust azimuth screw (No. 4 Fig. 3) for maximum output on the VU meter, tighten azimuth lock screw to freeze adjustments. By plugging the cue head output into the program input jack, the above procedure can be repeated to azimuth the cue head. On machines using a separate head for recording, the procedure is performed for the play head only. To azimuth the record head, insert a fully erased cartridge into the unit, engage the record mode and feed a 10 KC signal into the re-

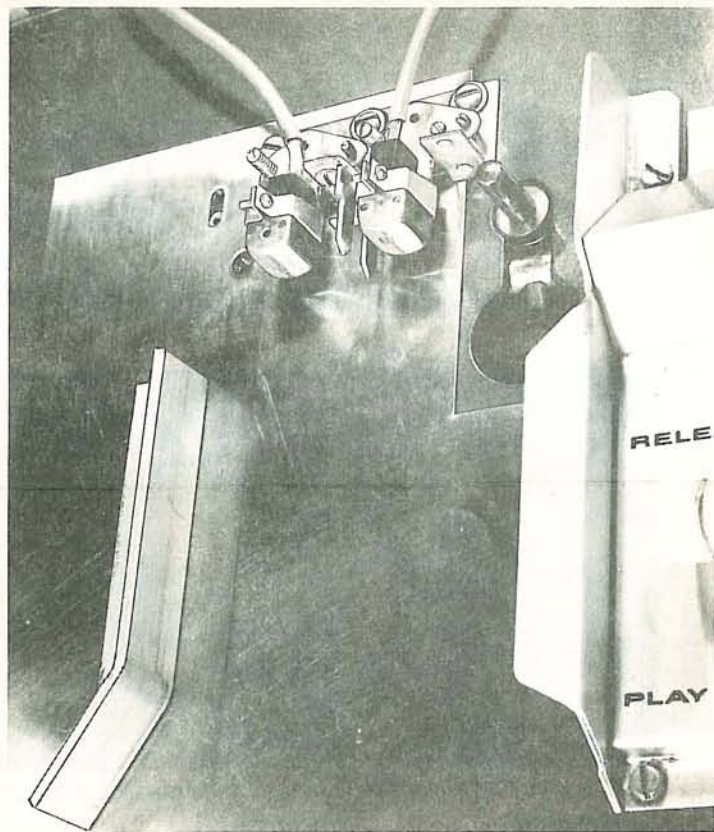

FIG. 5. SPOTMASTER, WITH GUIDE RAIL INSTALLED

ording amplifier. The record head is then azimuthed to provide maximum signal from the playback head as shown by the VU meter monitoring the playback amplifier.

PLAYBACK EQUALIZATION

Use a standard alignment tape to check the playback equalization. If Nortronics laminated core playback heads are being used to replace solid core type heads, the high frequency response may be excessive. This can be corrected by a readjustment of the internal equalization potentiometer. (See owners service manual for more detailed information on each individual machine.)

BIAS CURRENT ADJUSTMENT

To realize as high a quality recording as possible with minimum distortion and maximum signal to noise ratio, the bias current used during recording must be adjusted to an optimum value for a given tape head and tape combination. Optimum or peak bias must be re-established for the equipment whenever a tape head is replaced as well as periodically during the life of the head. On machines using separate record and playback heads, this is simply done. Feed a constant 1 KC signal into the recording amplifier at normal program level and adjust the bias current potentiometer until a maximum or peak signal level is noted on playback. On machines which use the one head for recording as well as playback, this same procedure may often-times be used by inverting the cue head and temporarily using it for monitoring or playback. (See owners service manual for more detailed information on each individual machine.)

NOTE: On certain machines which were equipped with the older type solid core heads, it may be difficult to gain sufficient bias current to achieve peak bias. Refer to Nortronics Form No. 7213 Cartridge Machine Technical Data for circuit modifications to provide increased bias current.

CARTRIDGE GUIDE RAIL (Use when none is provided)

An aluminum guide rail is included in each kit. Installed on the deck plate to the left of the cartridge, it provides correct and positive guiding, eliminating the possibility of damage to the heads by careless insertion or removal of the cartridge (see Fig. 5). With a cartridge in the play position, place the guide rail against it and mark the mounting holes on the deck plate. Center punch and drill the mounting holes using a #33 drill. Mount the guide rail using the washers and the 6-32 self tapping screws provided. Adjust the rail for proper clearance before tightening mounting screws.

PRESSURE PADS

It is important that when the tape heads enter the cartridge as it is inserted into the operating position, the pressure pads are depressed just sufficiently to insure good tape to head contact. Excessive pad pressure causes rapid deterioration of both the head and the tape and may introduce wow and flutter due to excessive tape drag. This is particularly true of the newer polyurethane pressure pads. Check several cartridges to determine the pressure pad engagement when in operating position. Adjust the heads forward or backward in the head bracket to achieve minimum pad pressure consistent with good high frequency response. Individual cartridges may require adjustment of the pressure pad assembly to conform to the standard selected.